

# BY100 Mini Fogger Manual



## INSTRUCTION MANUAL

When fogging outdoors, you should only fog for short periods at a time and when there is not much wind. When fogging indoors you should start at the furthest part of the building and work your way back until you get to the entrance or exit.

It is essential to read the chemical manufacturer's instructions before you start applying, including diluting ratio and safety precautions.

Only experienced personnel should operate this equipment.

You must exercise caution when connecting the propane/butane canister, in order to avoid the risk of fire.

## CAUTION MARKS



Please read this manual before using this equipment.



You must wear protective equipment (face/breathing mask, protective clothing, gloves, etc.) when handling potentially hazardous chemicals.



It is advised to wear ear plugs to protect the user from the high noise produced by the machine.



The interior of the machine heats up to extremely high temperatures. Do not add fuel or chemicals during the operation of the machine or when it is hot after use.



Avoid fogging chemicals upwind.



Flammable butane gas (Cartridge Type)

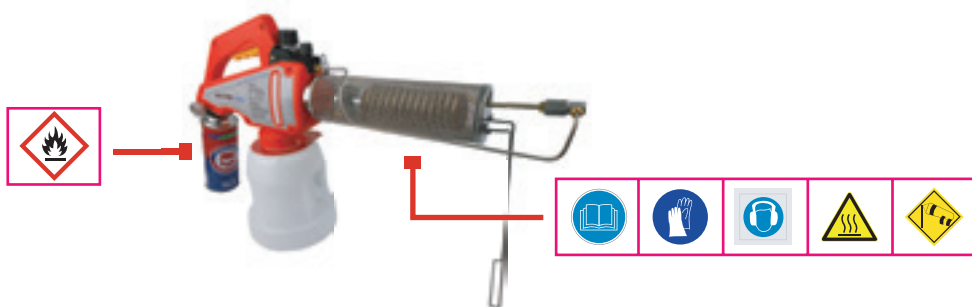

## SPECIFICATIONS

<b>Model</b>	<b>BY100 Mini Fogger</b>
<b>Dilutant Tank (Water or Oil)</b>	2.8 Liters
<b>Chemical Tank</b>	400 ml
<b>Fogging</b>	Dual Function: Water or Oil based
<b>Flow Rate</b>	2 LPH
<b>Fuel</b>	Propane/Butane Gas Cartridge
<b>Chemical Output</b>	1-5 Liters
<b>Net Weight</b>	1.70 Kg
<b>Gross Weight</b>	2.50 Kg
<b>Dimensions</b>	610x175x400 (mm)
<b>Accessories</b>	<ol style="list-style-type: none"> <li>1. BY100 Mini Fogger</li> <li>2. Plastic Pump</li> <li>3. Shoulder Strap</li> <li>4. Manual</li> </ol>

Vectorfog® BY100 Mini Foggers are powered by a standard propane or butane gas cartridge. The gas is ignited by a piezo and the gas heats the metal coil tube. The water or oil dilutant is then heated and mixed with the chemical to create a fog or mist. Thanks to its portability, the BY100 is ideal for fogging pesticides and disinfectants in a multitude of locations such as in homes, patios, parks, silos, chicken coops and greenhouses.

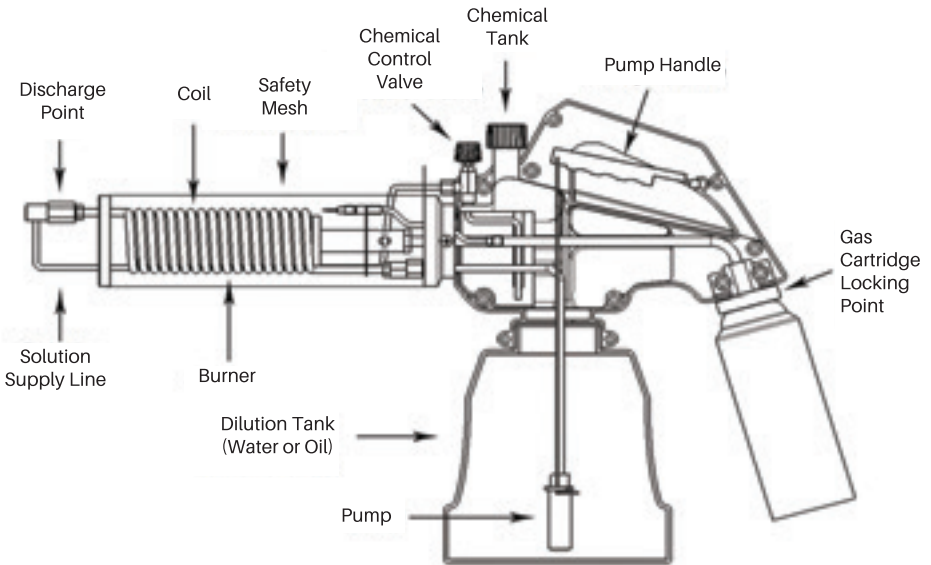

### Customer Service

Vectorfog®  
 10 Industrial Ave, Suite 4, Mahwah, NJ 07430, USA  
[info@vectorfog.com](mailto:info@vectorfog.com)    Tel: +1 844 780 6711    [www.vectorfog.com](http://www.vectorfog.com)

## CHECKLIST BEFORE STARTING THE UNIT

### Unpacking the Unit

When unpacking the unit, please make sure that the machine is not damaged and that all accessories mentioned in this manual are not missing.

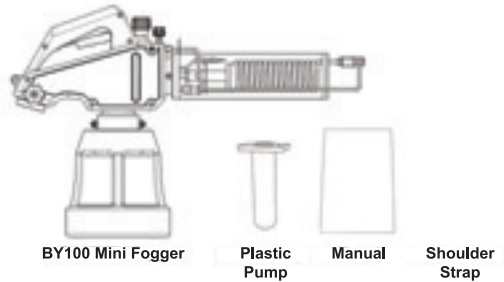

### Fill the Fuel Tank

Unscrew the tank counter-clockwise from the main body. Fill the tank with the dilutant of your choice. Water for water based fogging or oil for oil based fogging. Do not add more dilutant than needed. Do not overfill the tank. When finished with filling the tank, screw the tank tightly back to the main body in a clockwise direction.

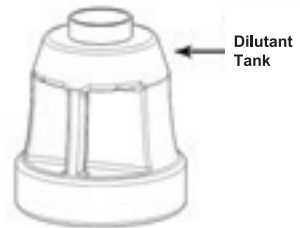

### Fill the Chemical Tank

Pre-mix chemical with an oil or water based emulsifier prior to filling the chemical tank. Please refer to chemical manufacturers instructions for correct ratio. Fill the special chemical mixture into the chemical tank. It is important not to add more chemical mixture than is needed. Please check level on the window located on the side of the machine. Maximum level is 350ml. When you finish filling the tank, close the tank cap tightly.

*Note: Leaving remaining chemicals in the tank after use could affect the performance of the machine in the following session as deposits may solidify.*

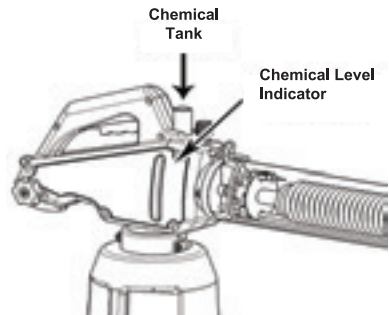

## To Turn Machine On

Connect the propane/butane gas cartridge to the main body. Make sure it is locked into position. Turn the gas supply on by turning the valve counter clockwise, as shown in the diagram. To start the machine, press the ignition switch located on the left hand side of the machine. It is necessary to keep the machine on for about 10 seconds (if water fogging) and/or 30 seconds (if oil fogging) to warm up before opening the chemical valve.

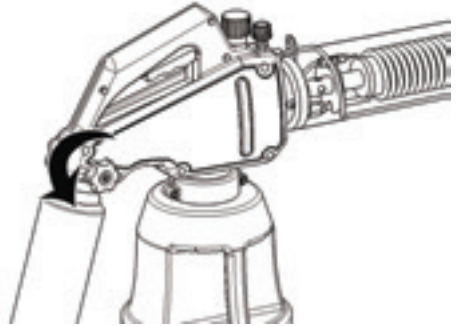

## To Start Fogging

Once the machine has warmed to the required temperature, turn the chemical valve counter clockwise as shown in the diagram below and press the trigger to start fogging. When the trigger is released, the fogging will pause.

*Note: When oil fogging, please make sure the oil has been consumed. Any oil still left in the coil after use could cause it to block and not work on the next session.*

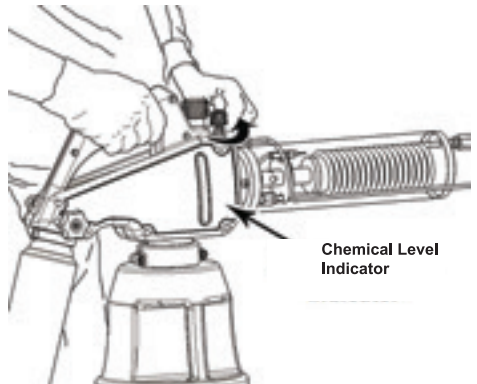

## To Turn Machine Off

Release the trigger. Turn the chemical supply valve clockwise to stop the supply of chemical. Turn off the gas supply by turning the valve clockwise as shown on the diagram below. Remove gas cartridge.

*Note: When storing the machine, please make sure no dilutant or chemicals are left in the tanks.*

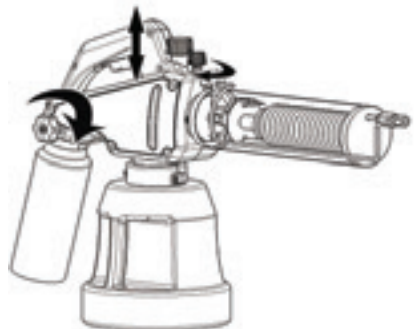

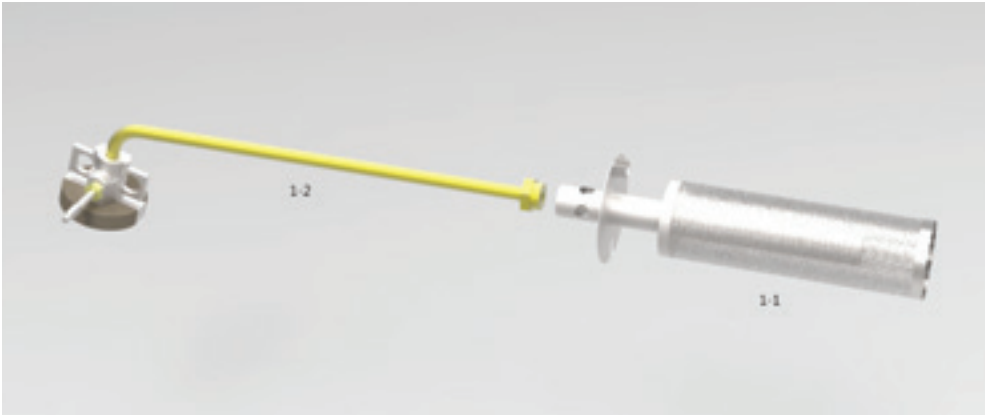

Part No.	Part Name
1-1	Burner Net Set
1-2	Burner Control Valve Set

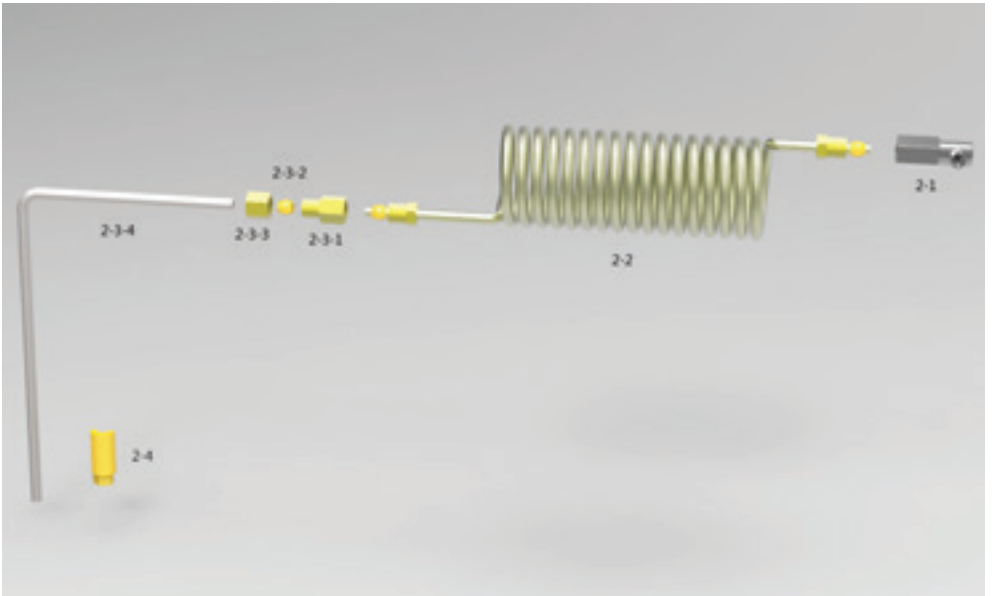

Part No.	Part Name
2-1	Jet Nozzle
2-2	Coil Set
2-3-1	Coil Connecting Bolt
2-3-2	Ring 6mm
2-3-3	Coil Nut
2-3-4	Pump Pipe
2-4	Pump Set

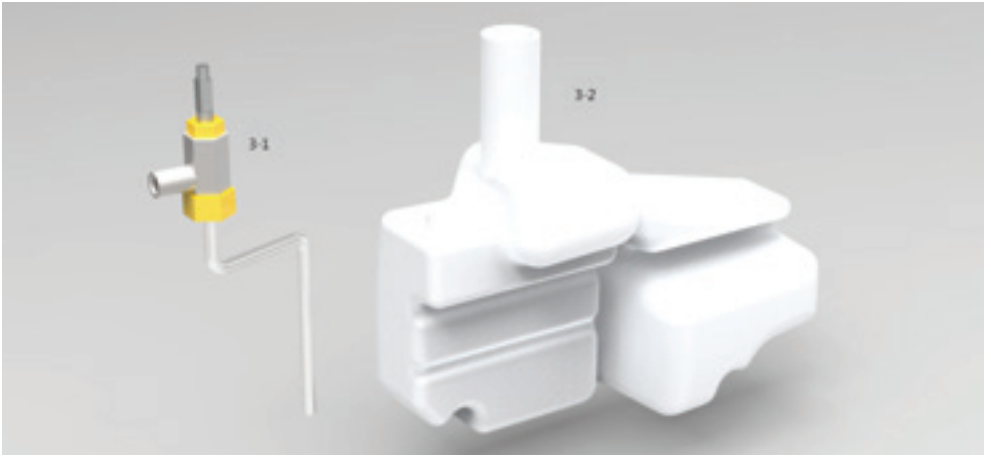

Part No.	Part Name
3-1	Chemical Control Valve Set
3-2	Chemical Tank



Part No.	Part Name
4-1-1	Chemical Supply Pipe
4-1-2	Ring 4mm
4-1-3	Chemical Supply Pipe Nut (S)
4-1-4	Chemical Supply Pipe Nut (B)



Part No.	Part Name
5-1	Insulator
5-2	Ignition Switch

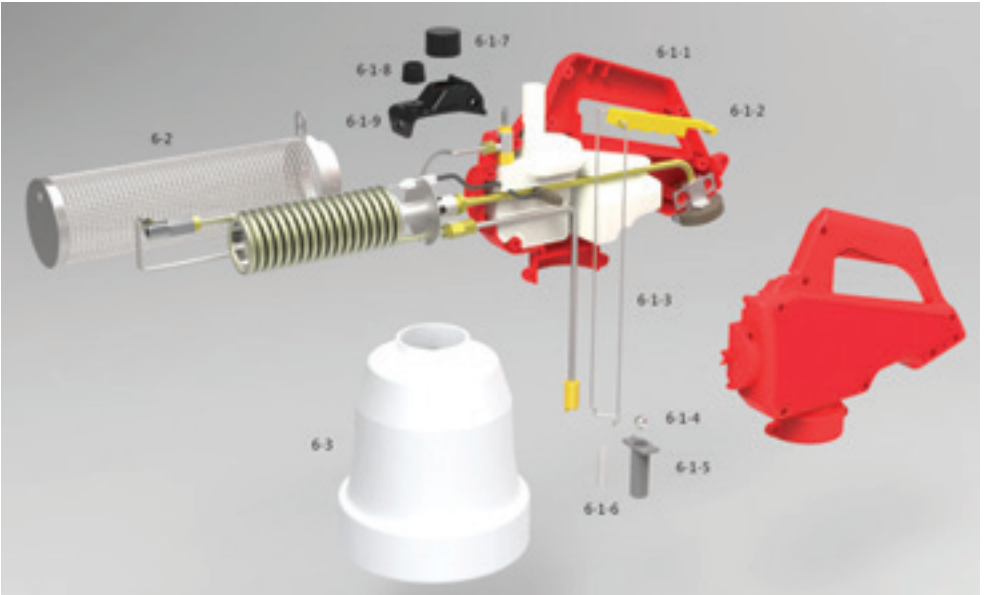

Part No.	Part Name
6-1-1	Case
6-1-2	Pump Handle
6-1-3	Pump Wire
6-1-4	Ball
6-1-5	Pump Plastic
6-1-6	Pump Spring
6-1-7	Chemical Tank Lid
6-1-8	Chemical Control Handle
6-1-9	Chemical Tank Cover
6-1-10	Cover Molding
6-2	Safety Net
6-3	Fuel Tank
6-4	Gas Control Handle



## PRODUCT WARRANTY



This product is warranted for twelve months from the date of original purchase. Any defect that arises due to faulty materials or workmanship will either be replaced or repaired during this period by the seller or authorized distributor from whom you purchased the unit. Transportation charges or duties shall be borne by Purchaser.

*Purchaser must register the product for warranty coverage on the website ([VECTORFOG.COM/WARRANTY](http://VECTORFOG.COM/WARRANTY)). Proof of purchase is required to register.*

### **The warranty is subject to the following provisions:**

- The warranty does not cover normal wear, accidental damage, misuse or damage resulting from use for a purpose for which it is not designed; altered in any way; or subjected to any but the specified voltage if applicable.
- The product must be operated only by trained and skilled personnel and it must be correctly handled and operated in accordance with the instructions contained within this manual. The functional safety of the unit (e.g. by trial fogging with water) must be checked before putting the unit in operation. Any loose or leaking valves or lines should be repaired and fixed. If functional safety is not ensured, do not put the unit into operation.
- The warranty will be rendered invalidated if the product is re-sold, fitted with non-original spare parts or damaged by inexpert repair.
- Chemical solutions must be officially approved for the intended application and the material safety data sheet of the chemical solution should be checked prior to operation. HOCL (Hypochlorous Acid) is a powerful oxidizing agent and is not recommended for use with this machine. Using a home-made HOCL solution with this machine is not covered under our 12 month warranty. If not approved for acid resistance, the pH-value should be limited to a range between 4 - 10 at 200 PPM. Using solutions out of the pH-value 4 - 10 will make the warranty null and void. After use, fog with clean water for about 3 minutes to remove any chemicals still left in the system. Ensure all the water is used up and the machine is dried prior to storage.  
**Damage caused by corrosion will invalidate the warranty!**
- Any formation of aerosols or fogs from flammable substances or acids releasing oxygen and a mixture with air and/or dust always involves the risk of fire and/or explosion if there is a source of ignition. Observe the explosion limit of all solutions and avoid over dosage accordingly. Only use non-inflammable liquids (without a flash point) for treatments in rooms where a dust explosion hazard exists. Unit is not explosion proof.
- Operators owe a duty of care to prevent unreasonable risk of harm or injury. Operators should not fog towards hot surfaces or electric cables nor fog in rooms where temperatures exceed 35°C. Position the unit in a safe and upright position with the hand piece hooked or carry it with the strap over your shoulder. In case of stationary use, do not leave the unit unattended.
- If the machine stops fogging unintentionally, turn off the unit immediately. If the issue persists, contact the supplier, distributor or Vectorfog®. After a return due to malfunctioning of the unit, the supplier, distributor or Vectorfog® will inspect the unit to determine whether or not warranty service applies. Upon arrival at the facility, inspection will take 7 - 14 business days. Vectorfog® will then contact the Purchaser with an evaluation of the product warranty.
- Specifications are subject to change without notice. The manufacturer disclaims any liability for the incidental or consequential damages. The warranty is in addition to and does not diminish your statutory or legal rights. In the event of a problem with the product within the warranty period call the Customer Helpline: (US) +1 844 780 6711 or email [cs@vectorfog.com](mailto:cs@vectorfog.com).